

**Table of Contents**  
**APS-35mm**  
**Change Over Instructions: REV B.**

Definitions.....1

A. Preparation .....2

B. Pre-Scanner Change Over.....2

    Figure 1.....3

C. Scanner Change Over.....5

    Figure 2.....6

    Figure 3.....8

D. Encoder Roller Change Over.....9

E. Final Setup.....10

Express Imaging Systems LLC  
624 Rainier Ave South  
Seattle, WA 98144  
206-720-1798



## **Definitions:**

### **Change Over Kits:**

These kits have the required parts necessary to allow the change between 35mm and APS formats. One kit is for a 35mm scanner with the 35mm Reconfiguration Kit installed, and one kit is for an APS scanner with the APS Reconfiguration Kit installed.

#### **APS to 35mm Change Over Kit, P/N: 88743339:**

This APS to 35mm Change Over kit contains the necessary parts to allow an APS Express Scan with an APS Reconfiguration Kit P/N 60081815 installed, to be converted between APS and 35mm formats. This change of film sizes takes about 30min.

#### **35mm to APS Change Over Kit, P/N: 63650738:**

This 35mm to APS Change Over kit contains the necessary parts to allow a 35mm Express Scan with a 35mm Reconfiguration Kit P/N 61217944 installed, to be converted between 35mm and APS formats. This change of film sizes takes about 30min.

## A. Preparation:

- 1) Shut down the Scanner application on the computer.
- 2) Turn off the Express Scan.
- 3) Shut down the Scanner Computer. From the Start menu choose “Shut Down Computer”, and then “OK”. (Start ? Shut Down Computer ? OK)
- 4) Retrieve the black box containing the Change Over Kit.

## B. Pre-Scanner Change Over:

### Parts Removal:

- 1) Remove the Pre-Scanner Light Shield by removing the two Knurled Knob Nuts holding it in place. Set aside. See Figure B1.
- 2) Remove the Pre-Scan Sensor Cover by removing the two screws. Set aside. See Figure B1.
- 3) Remove the Top Rocker Arm Assembly, by removing the mounting screw. Set these parts aside. See Figure B2 and Figure 1.
- 4) Unplug the Splice Sensor Cable from the Bottom Rocker Arm Assembly. See Figure B2.
- 5) Remove the Bottom Rocker Arm Assembly by removing the mounting screw. Set these parts aside. See Figure B2 and Figure 1.
- 6) If going from APS to 35mm format, remove the Perforation Sensor. See Figure B3 and Figure 1.

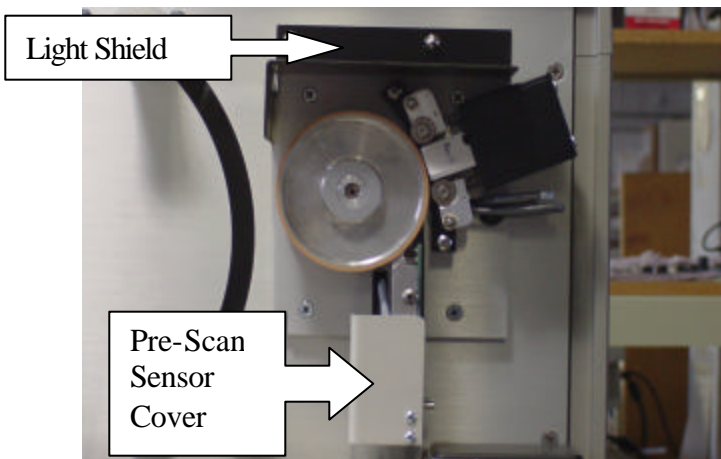

Figure B1

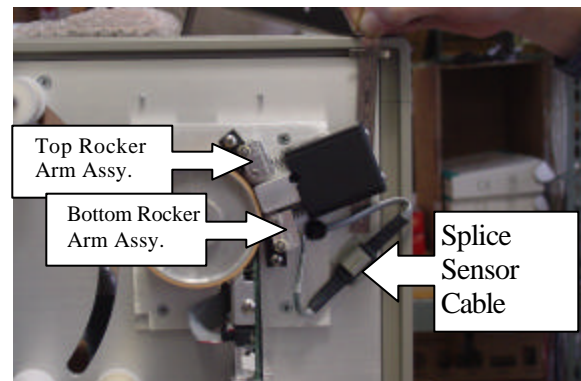

Figure B2

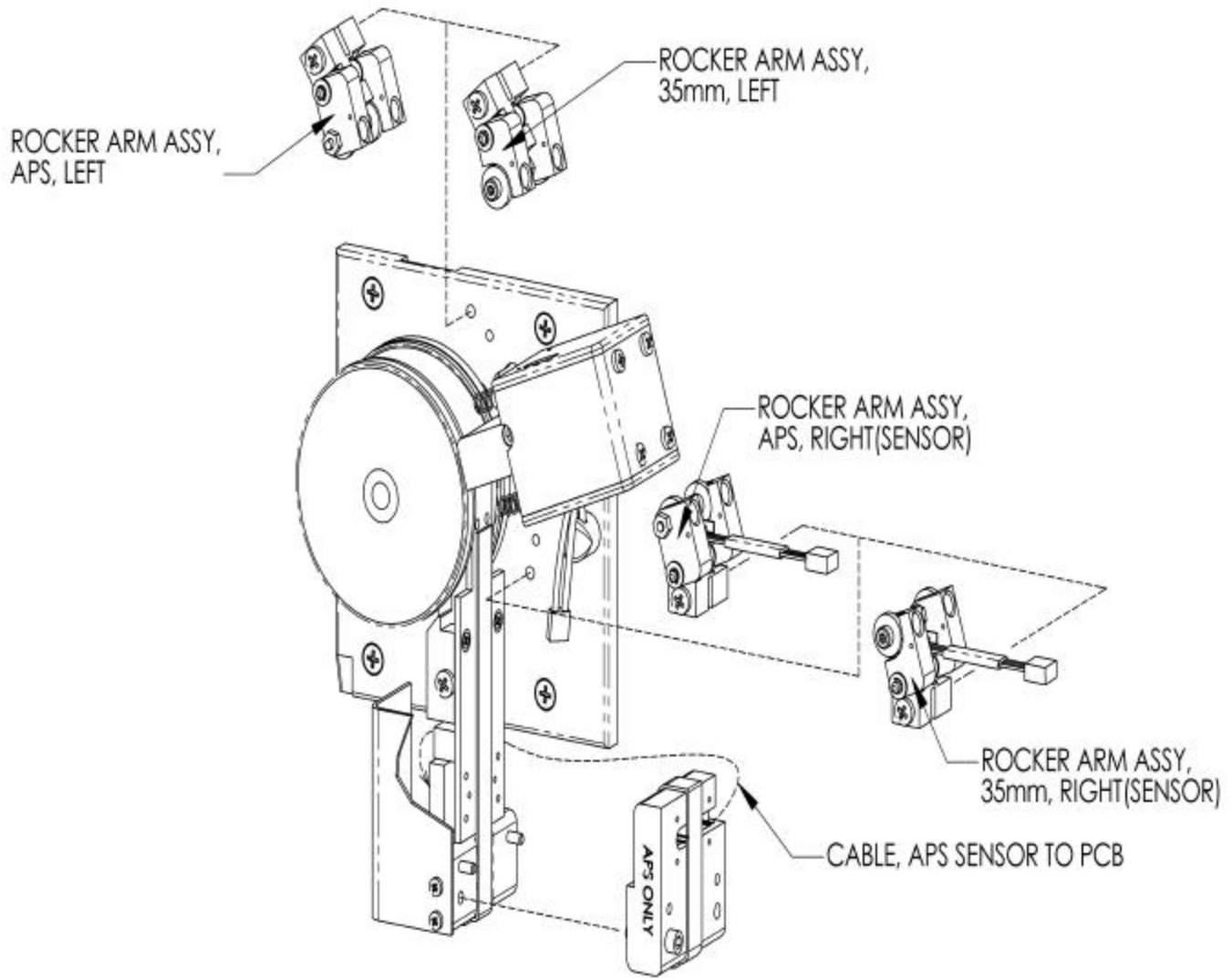

Figure 1

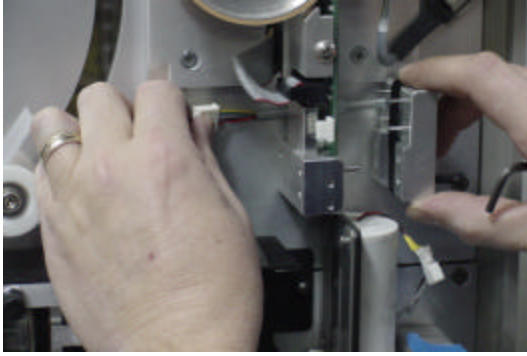

Figure B3

### Parts Installation:

- 1) Take the Bottom Rocker Arm Assembly from the Kit box and using the screw set aside from step 5, install it in place, making sure the springs are fully seated in the holes in the tracking wheel mounts. See Figure B2. Fully tighten the retaining screw. **Warning – do not over tighten the screw.**
- 2) Plug the Splice Sensor Cable together again. See Figure B2.
- 3) Take the Top Rocker Arm Assembly from the Kit box and using the screw set aside from step 3, install it in place, making sure the springs are fully seated in the holes in the tracking wheel mounts. See Figure B2. Fully tighten the retaining screw. **Warning – do not over tighten the screw.**
- 4) If going from a 35mm to APS format, remove the Perforation Sensor Block from the Kit box, and install it on the Pre-Scan sensor. Plug the cable into the header on the Pre-Scan sensor board. See Figure B3. **Warning – do not over tighten the mounting screw.**
- 5) Install the Pre-Scan Sensor Cover using the two screws. See Figure B1.
- 6) Install the Pre-Scanner Light Shield by using the two Knurled Knob Nuts. See Figure B1.

### Clean Up:

- 1) Take both Rocker Arm Assemblies that had been removed to start the change over and place them in the correct locations in the Kit box.
- 2) If the change over was from APS to 35mm, place the Perforation Sensor Block into the correct location in the Kit box.

## C. Scanner Change Over:

### Parts Removal:

- 1) Remove the Film Clamp by loosening the thumbscrew holding it to the shaft adapter. Set the parts aside. See Figure C1 and Figure 2.

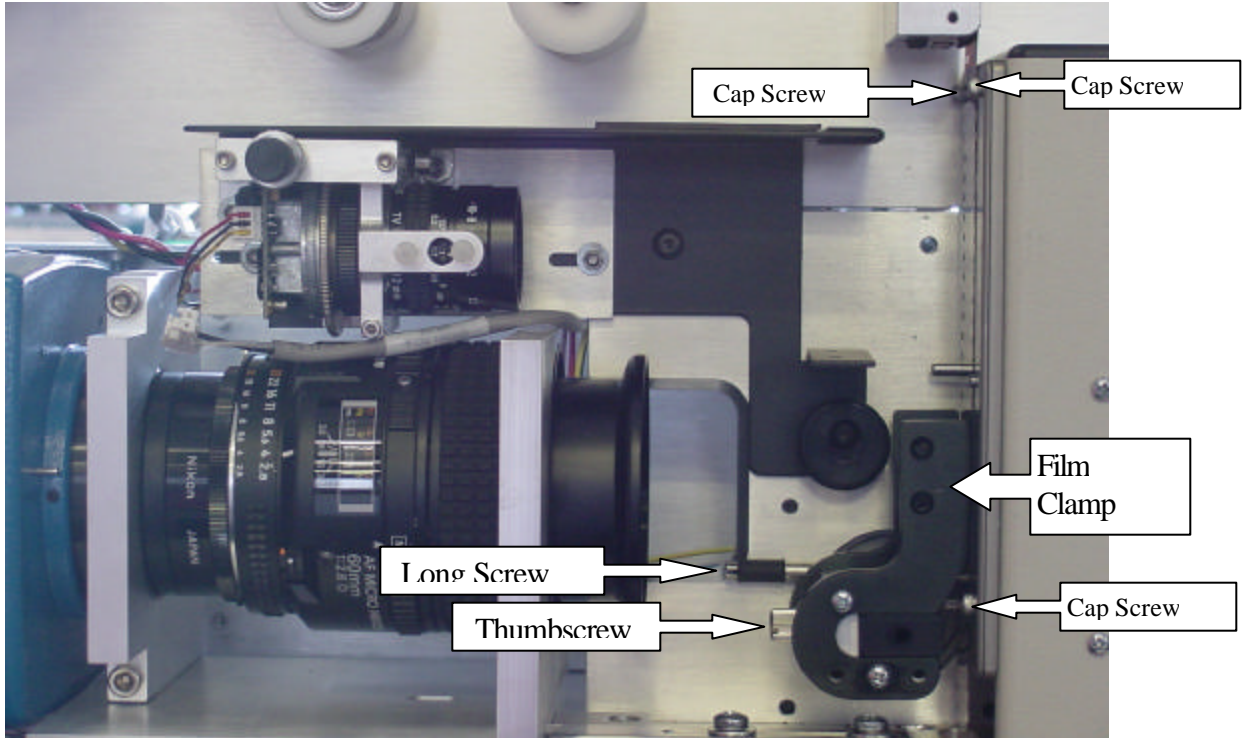

Figure C1

- 2) Remove the outside film mask by removing the two cap screws. See Figure C1 and Figure 3, Items 4. Set parts aside.
- 3) Remove the inside mask by removing the one cap screw on top and the long screw on the bottom. Set parts aside. See Figure C1 and Figure 3, Items 4 and 5.

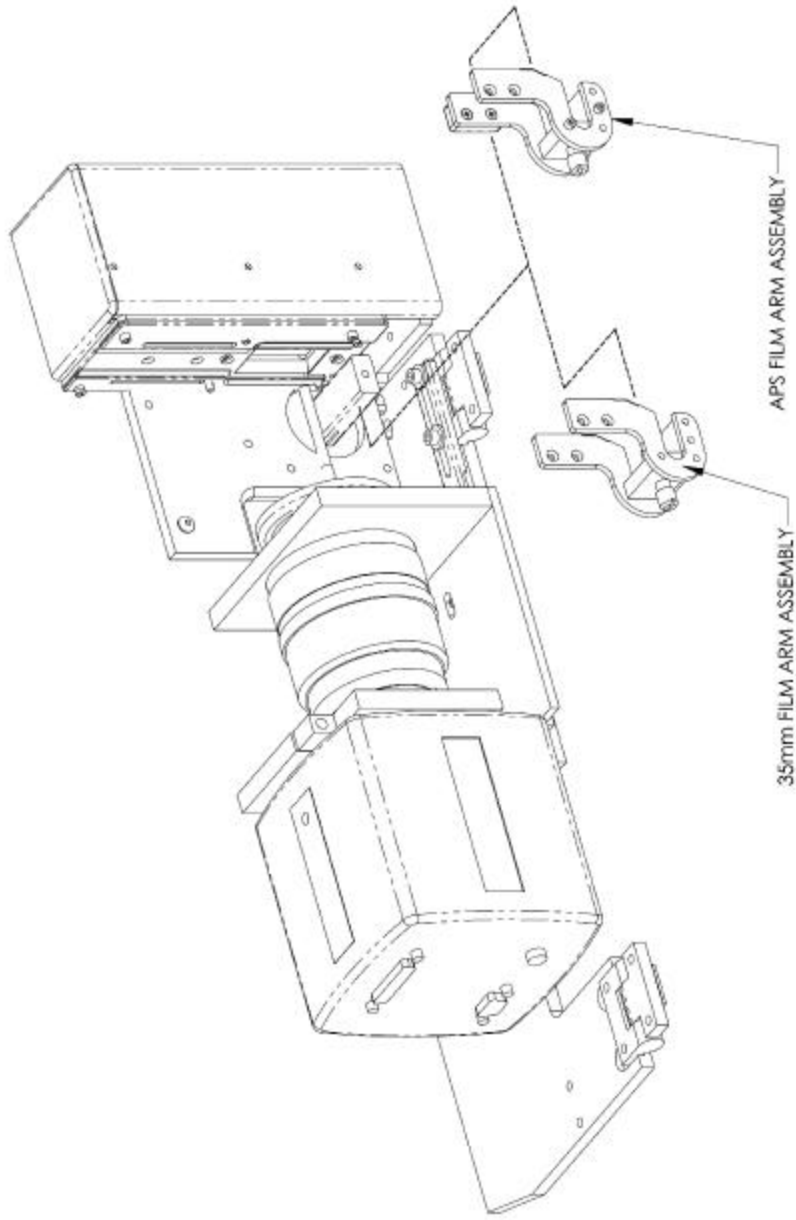

Figure 2

- 4) Optionally, if changing from 35mm to APS, the splice light can be removed. To remove, remove the two button head screws in the bottom of the DX Camera Mount. See Figure C2.

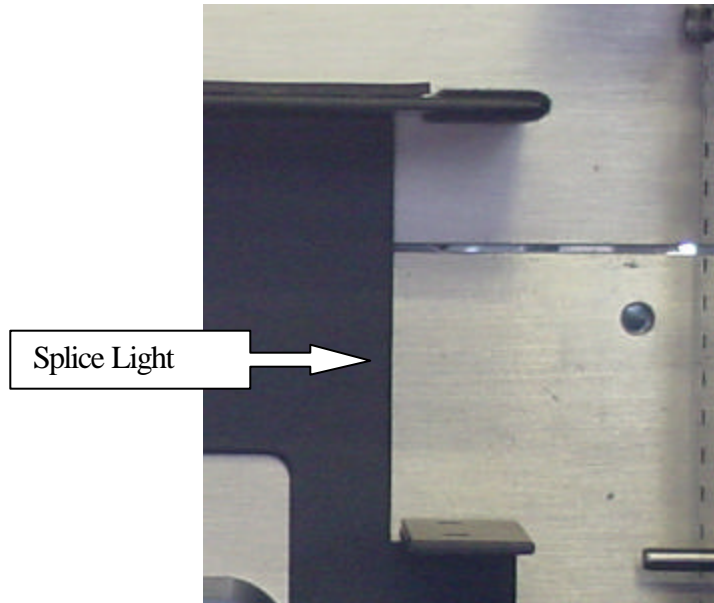

Figure C2

#### **Parts Installation:**

- 1) If changing from APS to 35mm, the splice light must be installed if it is not already installed. Get the splice light and mounting screws from the Kit box, and install it on the lower flange of the DX Camera Mount. See Figure C2.
- 2) Get the inside mask from the kit box, and using the cap screw and long screw set aside from step 3, Parts Removal, install the new inside mask. See Figure C1 and Figure 3, Items 4 and 5.
- 3) Get the outside mask from the kit box, and using the two cap screws set aside from step 2, Parts Removal, install the new outside mask. See figure C1 and Figure 3, Items 4.
- 4) Get the Film Clamp from the Kit box, and using the captive thumbscrew, mount it to the shaft adapter. See Figure C1 and Figure 2.

#### **Clean Up:**

- 1) Take the film clamp assembly that was removed during the change over, and put it in the Kit box in the correct location.
- 2) Take the two masks that were removed during the change over, and put them in the Kit box in the correct location.

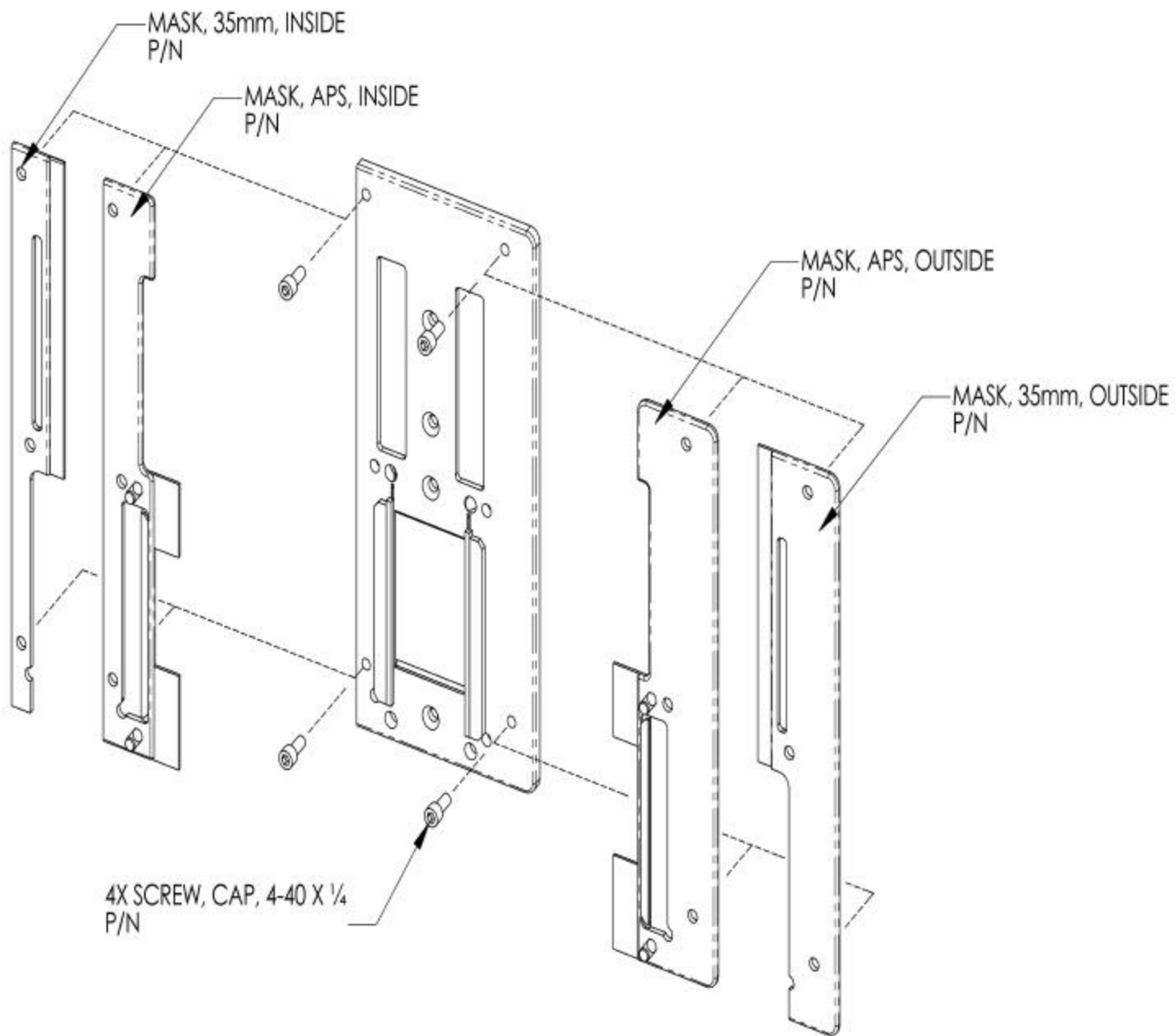

Figure 3

- 3) If the splice light was removed during the change over, put it and the two mounting screws in the Kit box in the correct location.

### **Adjustments:**

- 1) Loosen the two cap screws that hold the camera. See figure C3.
- 2) If changing to APS, move the camera assembly as far to the right as it will go, then tighten the two cap screws. See figure C3.
- 3) If changing to 35mm, move the camera assembly as far to the left as it will go, then tighten the two cap screws. See figure C3.

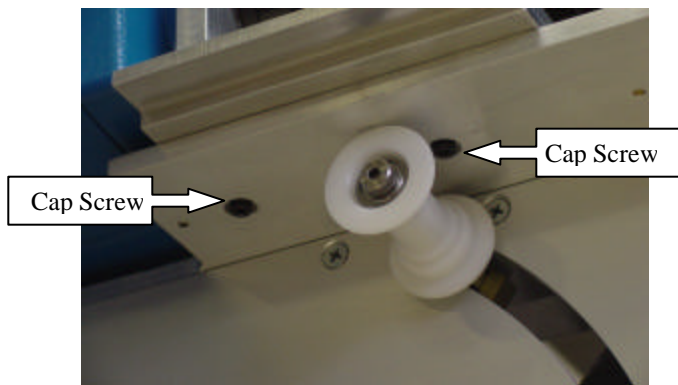

Figure C3

### **D. Encoder Roller Change Over:**

#### **Parts Removal:**

- 1) Remove the screw that retains the encoder roller. Set it aside for later. See Figure D1.

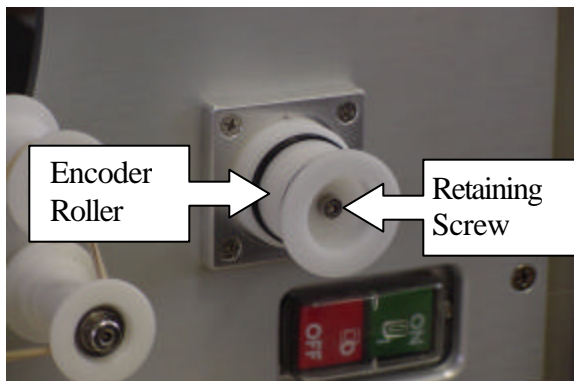

Figure D1

- 2) Remove the encoder roller and set it aside. See Figure D1.

### **Parts Installation:**

- 1) Get the Encoder Roller from the kit box.
- 2) Carefully line up the black indicator mark on the roller with the pin on the shaft, and slide the new roller on.
- 3) When it is fully seated, attach with the retaining screw from step 1, parts removal. See Figure D1.

### **Clean Up:**

- 1) Take the encoder roller that was removed during the change over, and put it in the Kit box in the correct location.

### **E. Final Set Up:**

- 1) Once the Change Over Kit has been installed, turn on the ExpressScan. Wait for the scanner to boot up. (Until the Take-up Motor stops turning.)
- 2) Turn on the Computer and wait for computer to boot up. Login once the computer has booted, if needed.
- 3) Start the ExpressScan program.
- 4) Load the Test Film with the Focus Target that is supplied with the kit.
- 5) Go to the Camera Calibration Screen and start the TEST, by clicking on the TEST button.
- 6) On the Calibration Screen find the Advance button. Advance the film until the Focus Target is in view.
- 7) Using the Focus Ring of the main camera. The Focus Ring is the knurled band at the front of the camera lens. Bring the image into focus. See Figure C1.
- 8) Once the image is in focus, stop the TEST, by clicking on the TEST button.
- 9) Exit the Camera Calibration Screen by clicking on the OK button.
- 10) Run a very small batch, 4 or 5 orders, to check quality of the work. Once the quality has been approved, the unit is ready for production.

You have finished installing the Change Over Kit.